

DRIVER, TRACK & RESULTS

DRIVER *Yugo Nagashima* **COUNTRY** *KOREA* **WEATHER** AIR TEMP TRACK TEMP DRY INTERMEDIATE WET
TRACK *GRC* **CONDITION** ASPHALT CARPET LOW MEDIUM HIGH BUMPY SMOOTH
RACE *AOC Rd2* **DATE** **QUALIFICATION** *3rd* **BEST LAP TIME** *15.2* **FINAL** *5th*

FRONT **DRIVE TRAIN** **REAR**
 GEAR DIFF GEAR DIFF *7500k*
 SPOOL

HEAVE DAMPER
 OIL *1000k* OIL *1500k*
 SPRINGS *yellow* SPRINGS *Red*
 SHIM mm SHIM mm

ROLL DAMPER
 OIL *5000k* OIL *5000k*
 SPRINGS *Red* SPRINGS *Red*
 HOLES HOLES

REAR REACTIVE SYSTEM
 RRS LINK NO RRS LINK
 SHIMS *2 mm*

CHASSIS FLEX CONFIGURATION TOP DESK
 STANDARD MAGNESIUM STIFF STANDARD
 ALU 2MM MAGNESIUM FLEX VERTICAL

TYRES Controlled
 BRAND/TYPE *sweep*
 INSERTS
 ADDITIVE *tireweek*
 TIME *5min*
 SURFACE

ELECTRONICS
 BATTERY *TRION 5500mAh SLCG*
 MOTOR *TRION V2* TIMING *std*
 ESC *TRION TRICO PRO V2* RECEIVER *RX-491*
 SERVO *POWER HD B7* RADIO *M17*

RATIO CONFIGURATION
 PINION *29* SPUR GEAR *112* PITCH *64*
 FINAL RATIO *7.72* ROLLOUT mm

AERODYNAMIC CONFIGURATION
 BODY WING
 BODY POSITION mm

REMARKS

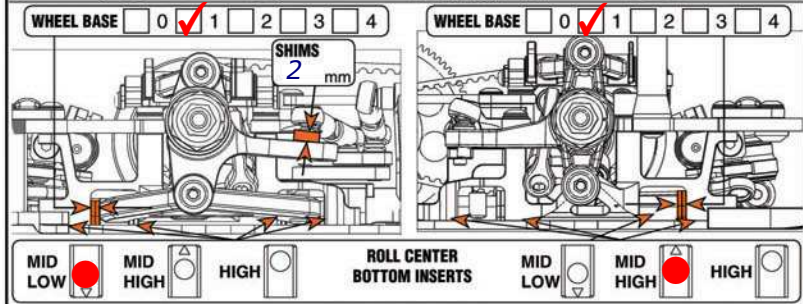
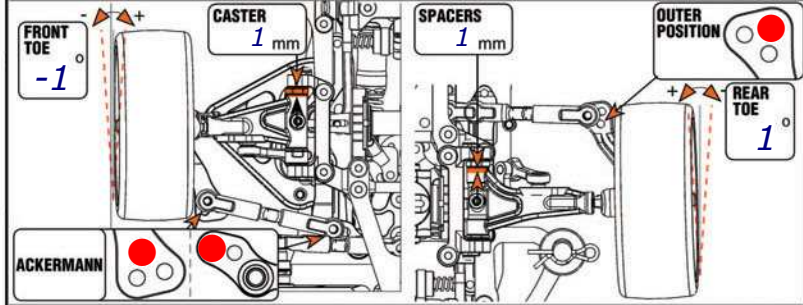
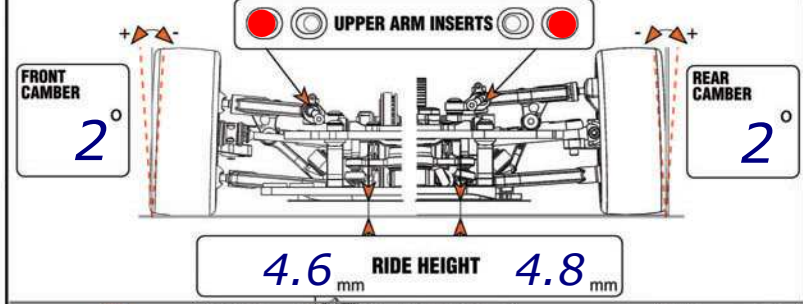
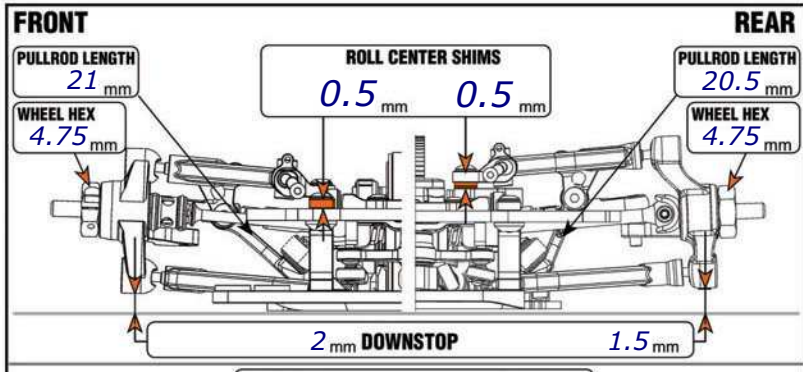

WEIGHT DISTRIBUTION
 BATTERY STD SHORTY SERVO LOCATION LEFT RIGHT
 BATT POSIT. FR MID RR CAR WEIGHT *1330 Grs*

