

RACE: ETRON TECH TROPHY  
 TRACK: \_\_\_\_\_  
 NAME: \_\_\_\_\_  
 CITY/COUNTRY: CASSINO  
 DATE: 18 nov 2013

TEMPERATURE: AIR 18 ° TRACK 0 °  
 QUALIFYING POSITION: 1 BEST LAP TIME: 15.920 SEC FINAL POSITION: 1 RACE LENGTH: \_\_\_\_\_ MIN  
 TRACK CONDITION:  TECHNICAL  MIXED  ASPHALT  FAST  
 TRACTION:  LOW  MEDIUM  HIGH

FRONT		REAR	
TRANSMISSION			
GEAR DIFF		GEAR DIFF	
<input checked="" type="checkbox"/> PUTTY 45	CST	<input type="checkbox"/> 2000	CST
ONE WAY		SOLID	
<input type="checkbox"/>	<input type="checkbox"/>	<input type="checkbox"/>	<input type="checkbox"/>
BALL DIFF		BALL DIFF	
<input type="checkbox"/> LOOSE	<input type="checkbox"/> MEDIUM	<input type="checkbox"/> LOOSE	<input type="checkbox"/> MEDIUM
<input type="checkbox"/>	<input type="checkbox"/> TIGHT	<input type="checkbox"/>	<input type="checkbox"/> TIGHT
MIDDLE SHAFT		FIXED <input checked="" type="checkbox"/> ONE WAY <input checked="" type="checkbox"/>	
PINION	27 T	SPUR GEAR	110 T
FINAL DRIVE RATIO	8.14	ROLLOUT	_____ mm
MOTOR	EZ POWER KICKER	TIMING	10°
ROTOR	12,4	ARMATURE	4.5
ESC	HW 3.0	BATTERIES	ez power 7200
BRUSHLESS	PROGRAM 129 beta	PUNCH	8-8
		INITIAL BRAKE	8%
		AUTO BRAKE	8%
BODY	LTC-R	WING	MR33

SHOCK ABSORBERS: FRONT OIL 500 CST SPRING HPI silver; REAR OIL 500 CST SPRING HPI silver  
 OPEN  CLOSED   
 ANTI-ROLL BAR THICKNESS: FRONT 1.4 mm REAR 1.4 mm

HOTRACE 32 TIRES: DIAMETER \_\_\_\_\_ mm; INSERTS \_\_\_\_\_; ADDITIVE mr33

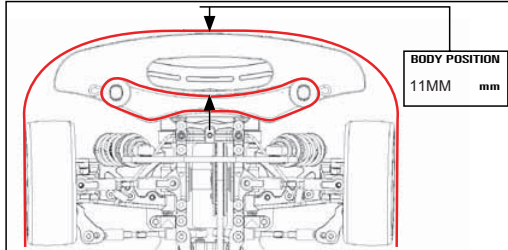

REMARKS  
 Front steering block inverted R/L  
 front 1.4 swaybar  
 rear 1.4 swaybar  
 Hard plastics - arm, chub, upright  
 chassis 2mm hard  
 Front geardiff with Ride Putty 45  
 new towermount front link position medium  
 new towermount front link position short  
 rear CVD driveshaft alu  
 shocks 10% rebound

FRONT

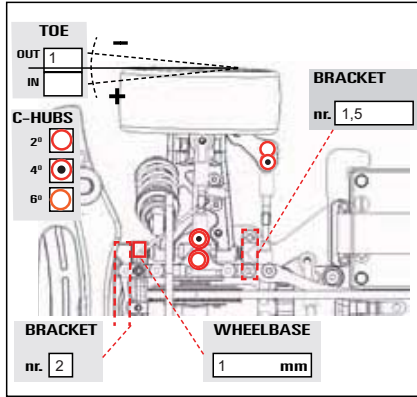

REAR

