

DRIVER, TRACK AND RESULTS

DRIVER	Justin Fales	COUNTRY	US	WEATHER	AIR TEMP	TRACK TEMP	<input checked="" type="checkbox"/> DRY <input type="checkbox"/> INTERMEDIATE <input type="checkbox"/> WET			
RACE	Wicked Weekend	DATE	8/18/19	QUALY POS.	7	STARTING POS.	7	FINAL POS.	3	FASTEST LAP
TRACK	TYPE <input type="checkbox"/> TIGHT <input type="checkbox"/> MEDIUM <input type="checkbox"/> OPEN <input checked="" type="checkbox"/>			GRIP <input type="checkbox"/> LOW <input checked="" type="checkbox"/> MEDIUM <input type="checkbox"/> HIGH						
SURFACE CONDITION	<input type="checkbox"/> SMOOTH <input type="checkbox"/> ROUGH <input checked="" type="checkbox"/> Very blown out track with dust									
TYPE	<input checked="" type="checkbox"/> HARD PACKED <input type="checkbox"/> CLAY <input type="checkbox"/> MULTI/SURFACE <input type="checkbox"/> GRASS <input type="checkbox"/> BLUE GROOVE <input checked="" type="checkbox"/> DIRT <input type="checkbox"/> ASTRO-TURF									

FRONT SHOCK ABSORBERS		REAR	
700 cst	OIL	650 cst	
purple	SPRINGS	blue	
0 mm	REBOUND	0 mm	
N° HOLES 5	∅ mm	PISTONS N° HOLES 5	∅ mm
<input checked="" type="checkbox"/> STRAIGHT <input type="checkbox"/> ANGLED	HOLES TYPE	<input checked="" type="checkbox"/> STRAIGHT <input type="checkbox"/> ANGLED	
<input type="checkbox"/> BLADDER <input checked="" type="checkbox"/> EMULSION	SEAL TYPE	<input type="checkbox"/> BLADDER <input type="checkbox"/> EMULSION	

ANTI-ROLL BARS	
FRONT ANTI-ROLL BAR	2.7 mm
REAR ANTI-ROLL BAR	2.7 mm

DIFFERENTIALS		
FRONT DIFF	CENTER DIFF	REAR DIFF
<input checked="" type="checkbox"/> HTD <input type="checkbox"/> STD	<input checked="" type="checkbox"/> HTD <input type="checkbox"/> STD	<input checked="" type="checkbox"/> HTD <input type="checkbox"/> STD
7 cst	10 cst	5 cst

GEARING	
CLUTCH BELL	13 Teeth
SPUR GEAR	46 Teeth

CLUTCH	
CLUTCH BELL	FLYWHEEL
<input type="checkbox"/> STANDARD <input checked="" type="checkbox"/> VENTED	<input type="checkbox"/> STEEL <input checked="" type="checkbox"/> ALU
CLUTCH SHOES	CLUTCH SPRINGS
SHOE TYPE carbon x 2 with	SPRINGS TYPE .90 mm
SHOE TYPE alum x 2 with	SPRINGS TYPE 1.0 mm

ENGINE, PIPE AND FUEL			
ENGINE BRAND	OS	TYPE	Drake
HEADSHIMS	mm	GLOWPLUG	CARB ∅ 6 mm
EXHAUST PIPE	2060	MANIFOLD	75
FUEL BRAND	Runner Time	NITRO	33 %

FLEX CONFIGURATION	
ENGINE MOUNT	<input checked="" type="checkbox"/> STANDARD <input type="checkbox"/> MONOBLOCK

AERODYNAMIC CONFIGURATION	
BODY	<input type="checkbox"/> STANDARD <input type="checkbox"/> HIGH DOWNFORCE <input checked="" type="checkbox"/> OTHER LFR Tactic
WING	
TYPE	Serpent
WING PLATES	<input type="checkbox"/> 2° <input checked="" type="checkbox"/> 4° <input type="checkbox"/> 6°
GURNEY STRIP	<input type="checkbox"/> YES <input checked="" type="checkbox"/> NO
CENTER FOIL	<input type="checkbox"/> YES <input checked="" type="checkbox"/> NO

FRONT TIRES		REAR	
AKA	MAKE	AKA	
P-ONE SLW	TYPE	P-ONE SLW	
AKA	INSERTS	AKA	
AKA	WHEELS	AKA	

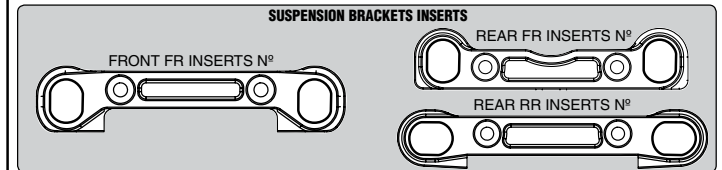
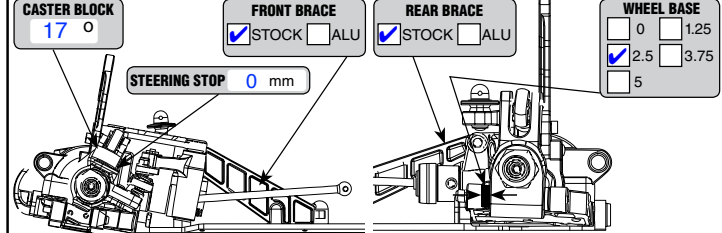
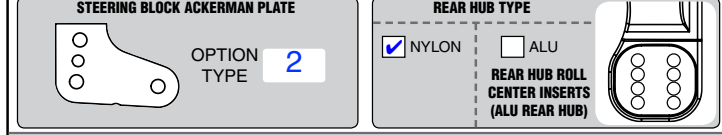
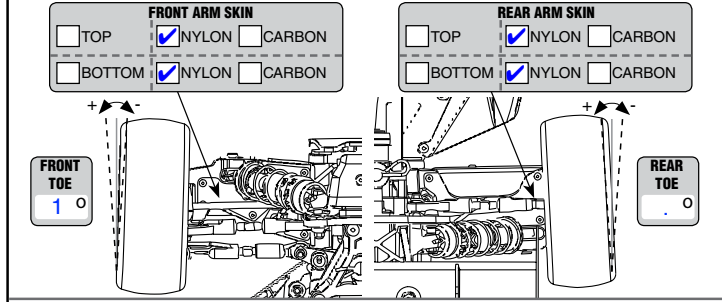
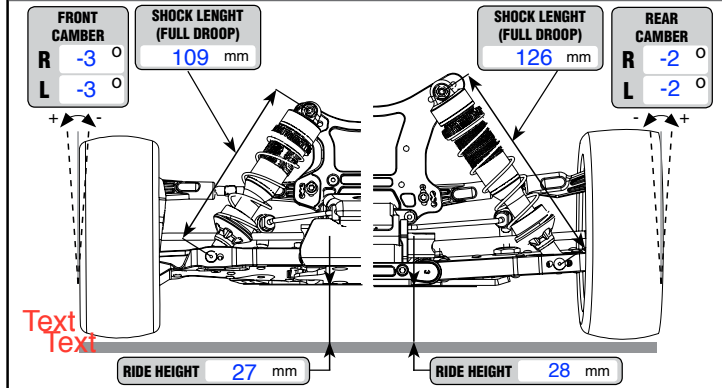
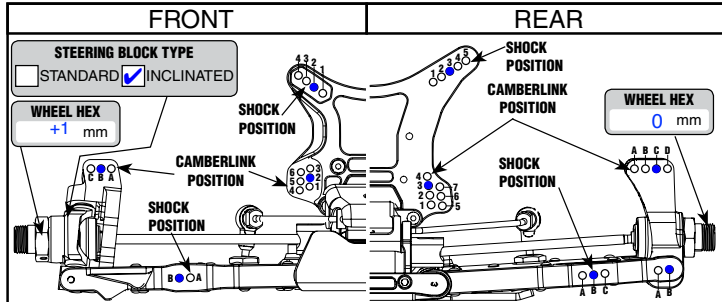

REMARKS: Air temp 92 degrees. istons 5 hole 1.4 front 5 hole 1.5 rear. Rear toe 3.25. Zero anti squat. Front kick up 11.