

DRIVER, TRACK AND RESULTS

DRIVER Pontus Larsson **COUNTRY** SWE **WEATHER** AIR TEMP 21 TRACK TEMP 21 DRY INTERMEDIATE WET
RACE DHI CUP **DATE** 180107 **QUALY POS.** 17 **STARTING POS.** B7 **FINAL POS.** 17 **FASTEST LAP**
TRACK ODENSE DANMARK **TYPE** INDOOR OUTDOOR **STYLE** TIGHT MEDIUM OPEN
SURFACE GRIP LOW MEDIUM HIGH Very high **CONDITION** SMOOTH ROUGH
TYPE HARD PACKED CLAY CARPET MULTI/SURFACE GRASS BLUE GROOVE DIRT ASTRO-TURF

FRONT SHOCK ABSORBERS		REAR
45WT cst	OIL	30 WT cst
Xray 4 dot	SPRINGS	Xray 3 dot
0 mm	REBOUND	0 mm
4 mm	LIMITERS	0 mm
N° HOLES 2	Ø 1,6 mm	PISTONS N° HOLES 2 Ø 1,7 mm
PISTONS TYPE <input type="checkbox"/> STOCK <input type="checkbox"/> CONICAL <input checked="" type="checkbox"/> SQUARE		
<input type="checkbox"/> SHORT <input checked="" type="checkbox"/> LONG		SPRING BUCKETS <input checked="" type="checkbox"/> SHORT <input type="checkbox"/> LONG
<input type="checkbox"/> BLADDER	SEAL TYPE	<input type="checkbox"/> BLADDER
<input checked="" type="checkbox"/> EMULSION		<input checked="" type="checkbox"/> EMULSION

FRONT ANTI-ROLL BARS		REAR
<input type="checkbox"/>	<input type="checkbox"/>	<input type="checkbox"/>
1.0	1.2	1.4
1.4	1.6	1.8
<input type="checkbox"/>	<input checked="" type="checkbox"/>	<input type="checkbox"/>
1.0	1.2	1.4
1.6	1.8	

TRANSMISSION	
FRONT DIFF 30 000 cst	REAR DIFF 20 000 cst
<input checked="" type="checkbox"/> SLIPPER	<input type="checkbox"/> CENTER DIFF

GEARING	
PINION 22 Teeth	SPUR GEAR 86 Teeth

ELECTRONICS	
BATTERY	
BRAND GENS ACE	CAPACITY 4200 mAh
MOTOR	
BRAND HW	TYPE 5,5
ESC	
BRAND HW	TYPE XR10 Pro

AERODYNAMIC CONFIGURATION	
BODY BRAND Serpent	TYPE std
REAR WING BRAND Sepent	TYPE std
REAR WING WIDTH 6,5	REAR WING LIP 0 mm
FRONT WING <input type="checkbox"/> YES <input checked="" type="checkbox"/> NO	TYPE

FRONT TIRES		REAR
Schumacher	MAKE	Schumacher
Cactus U6840	TYPE	Cactus U6838
Yellow	COMPOUND	Yellow
Medium U6733	INSERTS	Medium U6734
Serpent	WHEELS	Serpent
No	ADDITIVE	No

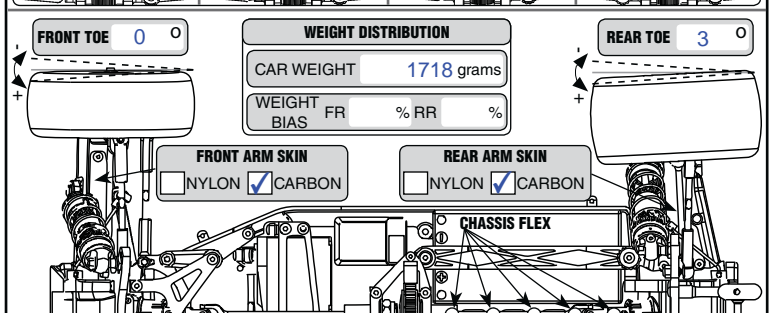
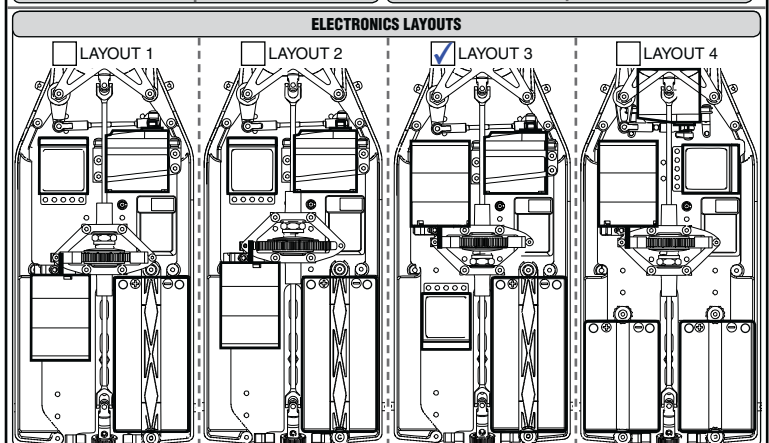
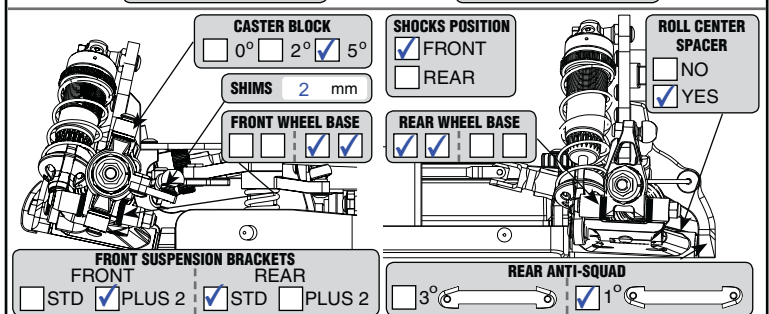
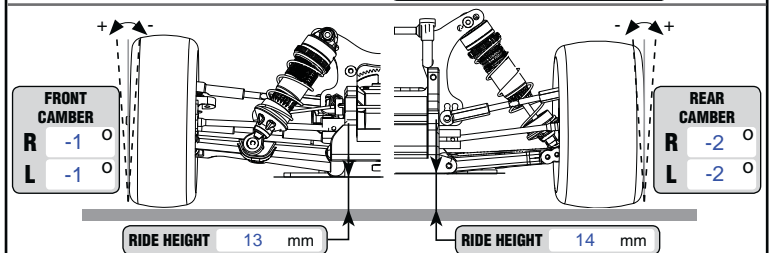
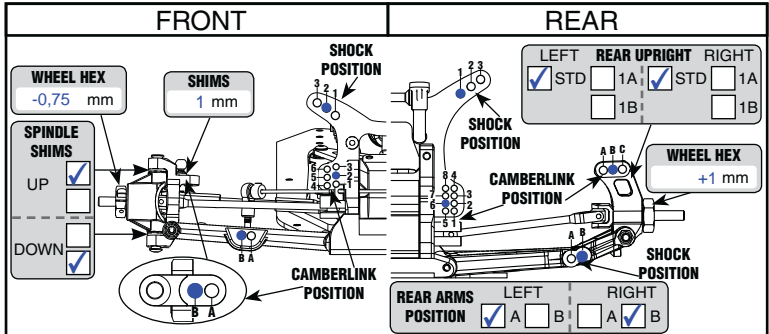

REMARKS
 B-final result: 6,6,6
 Car was very good and fast.
 With new tyres there was too much grip. V2 front and rear shocktower.
 Rear tyres cut inside and outside.
 Front tyres glued up to 2nd row outside and first row inside.
 Car is very good when tyres are worn out 50% or more.