

DRIVER, TRACK AND RESULTS

DRIVER **Dominic Greiner** COUNTRY **Germany** WEATHER AIR TEMP **30** TRACK TEMP **45** DRY INTERMEDIATE WET

TRACK **Fort Myers** TRACTION LOW MEDIUM HIGH COMMENTS

RACE **Winternats** DATE **17.02.2018** QUALY POS. **1** QUALY TIME STARTING POS. **1** FINAL POS. **1**

FRONT	DRIVE TRAIN	REAR
<input checked="" type="checkbox"/> GEAR DIFF 2.000.000 cst	GEAR DIFF 100.000 cst	
<input type="checkbox"/> SPOOL		

1ST	SPUR GEARS	2ND
<input type="checkbox"/> 58 <input checked="" type="checkbox"/> 59 <input type="checkbox"/> 60	<input type="checkbox"/> 53 <input checked="" type="checkbox"/> 54 <input type="checkbox"/> 55	

1ST	PINION	2ND
<input type="checkbox"/> 15 <input checked="" type="checkbox"/> 16 <input type="checkbox"/> 17	<input type="checkbox"/> 20 <input checked="" type="checkbox"/> 21 <input type="checkbox"/> 22	

FRONT	SHOCK ABSORBERS	REAR
900 cst OIL	900 cst	
blue SPRINGS	blue	
6 mm REBOUND	6 mm	
<input type="checkbox"/> <input type="checkbox"/> <input checked="" type="checkbox"/> <input type="checkbox"/>	<input type="checkbox"/> <input type="checkbox"/> <input checked="" type="checkbox"/> <input type="checkbox"/>	

FRONT	ANTI-ROLL BARS	REAR
<input type="checkbox"/> 1.8 <input type="checkbox"/> 2.2 <input checked="" type="checkbox"/> 2.5 <input type="checkbox"/> 2.8	<input type="checkbox"/> 1.6 <input type="checkbox"/> 1.8 <input checked="" type="checkbox"/> 2.0 <input type="checkbox"/> 2.2 <input type="checkbox"/> 2.5	

FRONT	TYRES	Controlled Tyre	REAR
Matrix MAKE	Air Rim		
37 SHORE	40		
61 DIAMETER	63		
5-MIN WEAR			

POWER PACK	
ENGINE	
BRAND Novarossi	TYPE Mito WC's
GLOWPLUG TFGB6 CARBØ 5,5 mm	HEAD CLEARANCE mm
EXAUSHT	
PIPE 2660	MANIFOLD short
FUEL	
BRAND RunnerTime	NITRO 16

CLUTCH	
CLUTCH BELL <input checked="" type="checkbox"/> ALU <input type="checkbox"/> STEEL	CLUTCH SHOE <input type="checkbox"/> RED <input checked="" type="checkbox"/> YELLOW <input type="checkbox"/> BLACK
CLUTCH SPRING X-spring	CLUTCH BELL GAP 0,5 mm

FLEX CONFIGURATION	
CHASSIS STIFFENER <input checked="" type="checkbox"/> YES <input type="checkbox"/> NO	FLEX <input type="checkbox"/> YES <input checked="" type="checkbox"/> NO

AERODYNAMIC CONFIGURATION	
BODY BRAND Xtreme	BODY POSITION 10 mm
BODY TYPE Avenge	
BUMPERS HOLES <input type="checkbox"/> YES <input checked="" type="checkbox"/> NO	

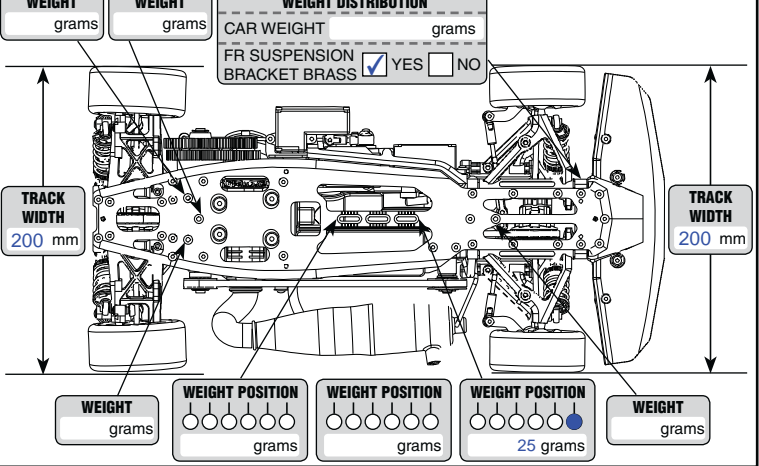
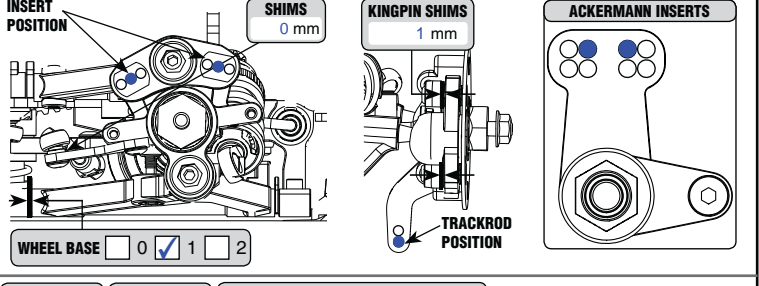
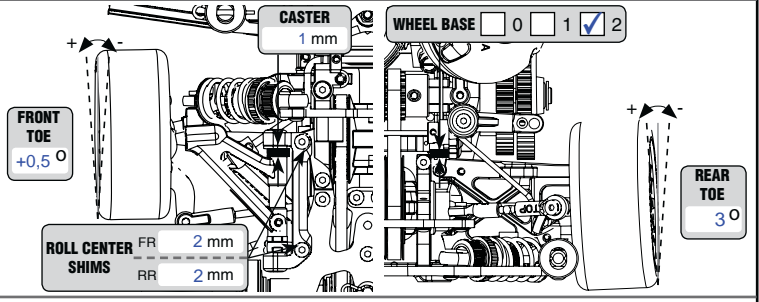
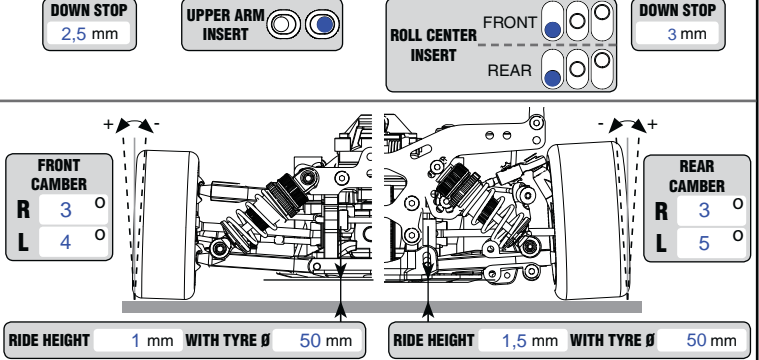
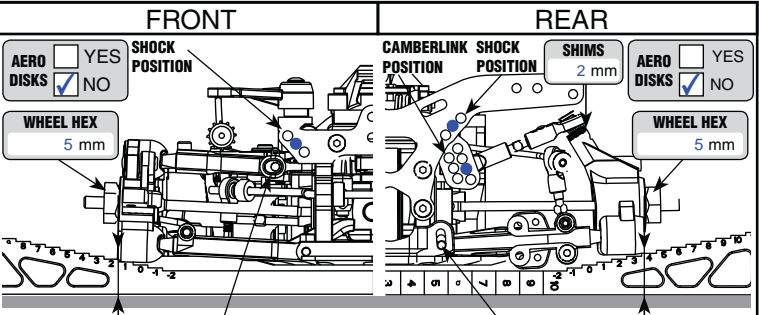

REMARKS **Setup with Arrowmax systems, Arrowmax titan screws on the top, Xrd alu clutch bell,**