

DRIVER, TRACK AND RESULTS

DRIVER Dominic Greiner **COUNTRY** Italy **WEATHER** AIR TEMP 23 TRACK TEMP 35 DRY INTERMEDIATE WET
TRACK RME Cassino **TRACTION** LOW MEDIUM HIGH **COMMENTS**
RACE EFRA GP **DATE** 26.03.2017 **QUALY POS.** 1 **QUALY TIME** **STARTING POS.** 1 **FINAL POS.** 2

FRONT	DRIVE TRAIN	REAR
<input checked="" type="checkbox"/> GEAR DIFF <u>2.000.000</u> cst	GEAR DIFF <u>80.000</u> cst	
<input type="checkbox"/> SPOOL		

1ST	SPUR GEARS	2ND
<input type="checkbox"/> 58 <input type="checkbox"/> 59 <input checked="" type="checkbox"/> 60		<input type="checkbox"/> 53 <input type="checkbox"/> 54 <input checked="" type="checkbox"/> 55

1ST	PINION	2ND
<input type="checkbox"/> 15 <input checked="" type="checkbox"/> 16 <input type="checkbox"/> 17		<input type="checkbox"/> 20 <input checked="" type="checkbox"/> 21 <input type="checkbox"/> 22

FRONT	SHOCK ABSORBERS	REAR
<u>900</u> cst	<u>OIL</u>	<u>900</u> cst
<u>red</u>	<u>SPRINGS</u>	<u>red</u>
<u>6</u> mm	<u>REBOUND</u>	<u>6</u> mm
<input type="checkbox"/> <input type="checkbox"/> <input checked="" type="checkbox"/> <input type="checkbox"/>		<input type="checkbox"/> <input type="checkbox"/> <input checked="" type="checkbox"/> <input type="checkbox"/>

FRONT	ANTI-ROLL BARS	REAR
<input type="checkbox"/> 1.8 <input type="checkbox"/> 2.2 <input checked="" type="checkbox"/> 2.5 <input type="checkbox"/> 2.8		<input type="checkbox"/> 1.6 <input type="checkbox"/> 1.8 <input type="checkbox"/> 2.0 <input checked="" type="checkbox"/> 2.2 <input type="checkbox"/> 2.5

FRONT	TYRES	Controlled Tyre	REAR
<u>Matrix</u>	<u>MAKE</u>	<input checked="" type="checkbox"/>	
<u>37</u>	<u>SHORE</u>		<u>40</u>
<u>62</u>	<u>DIAMETER</u>		<u>64</u>
	<u>5-MIN WEAR</u>		

POWER PACK	
ENGINE	
BRAND <u>Novarossi</u>	TYPE <u>Mito WC</u>
GLOWPLUG <u>TGFB6</u>	CARBØ <u>5,5</u> mm HEAD CLEARANCE <u>mm</u>
EXAUSHT	
PIPE <u>2660</u>	MANIFOLD <u>short</u>
FUEL	
BRAND <u>Runner Time</u>	NITRO <u>16</u>

CLUTCH	
CLUTCH BELL <input checked="" type="checkbox"/> ALU <input type="checkbox"/> STEEL	CLUTCH SHOE <input type="checkbox"/> RED <input checked="" type="checkbox"/> YELLOW <input type="checkbox"/> BLACK
CLUTCH SPRING <u>Serpent X-hard</u> CLUTCH BELL GAP <u>0,5</u> mm	

FLEX CONFIGURATION	
CHASSIS STIFFENER <input checked="" type="checkbox"/> YES <input type="checkbox"/> NO	FLEX <input type="checkbox"/> YES <input checked="" type="checkbox"/> NO

AERODYNAMIC CONFIGURATION	
BODY BRAND <u>SRC</u>	BODY POSITION <u>10</u> mm
BODY TYPE <u>Spark</u>	
BUMPERS HOLES <input checked="" type="checkbox"/> YES <input type="checkbox"/> NO	

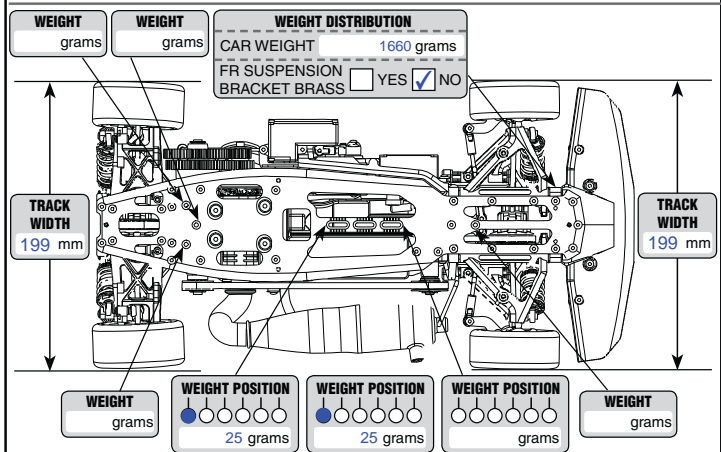
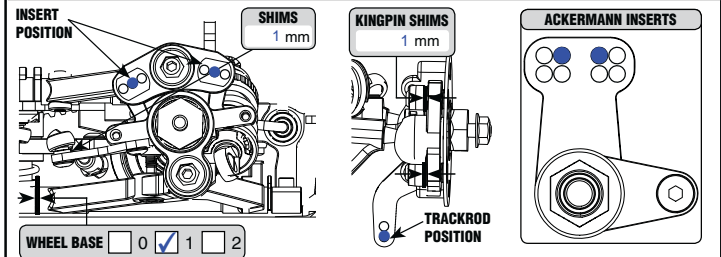
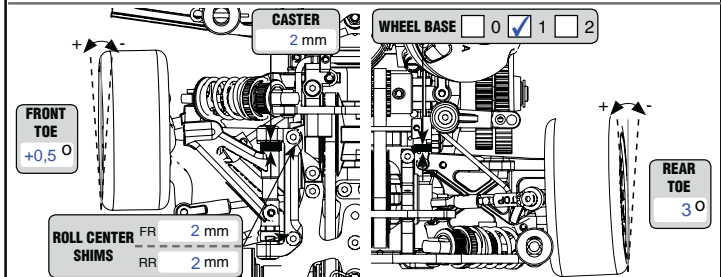
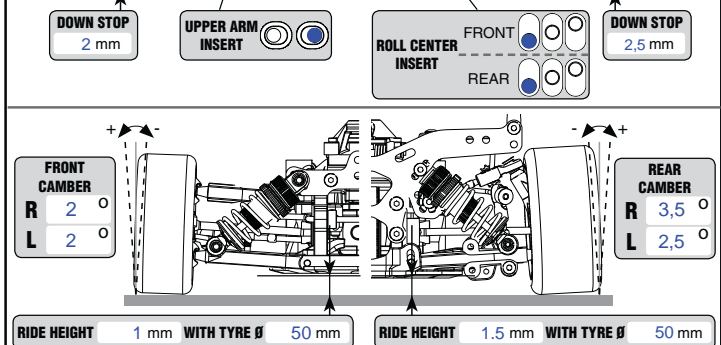
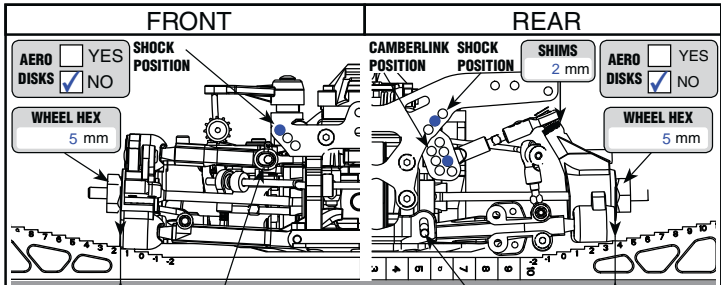

REMARKS Setup and shock oil Arrowmax, titan screws on top, xrd blue clutch bell, downstop in real mm!! Fastest lap 15.14