

A

# DIFFERENTIAL CENTER

1

CENTER  
DIFF  
BAG

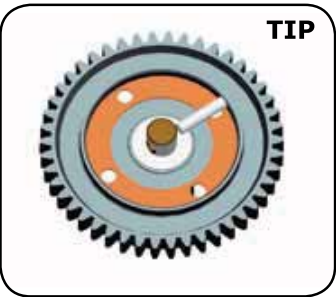
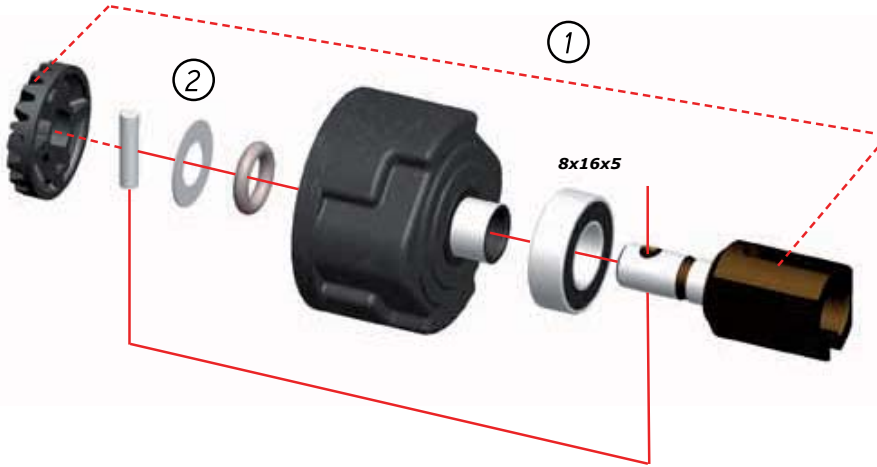

A

2

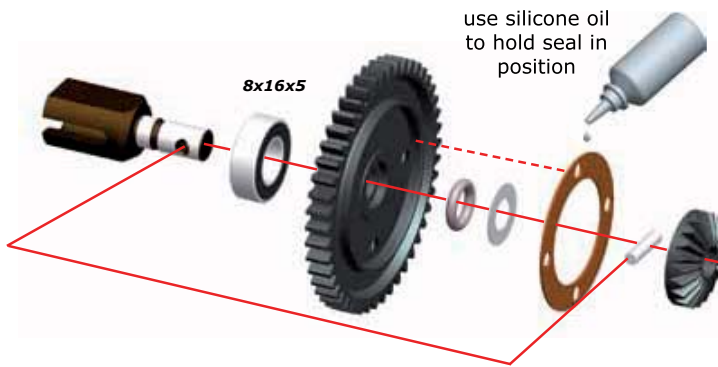

A

3

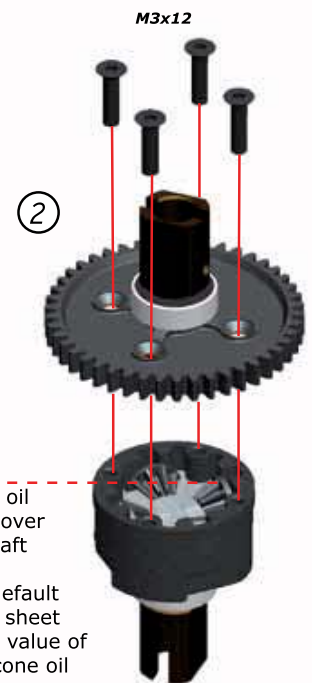

4

# REAR AXLE

A

9

BAG  
2

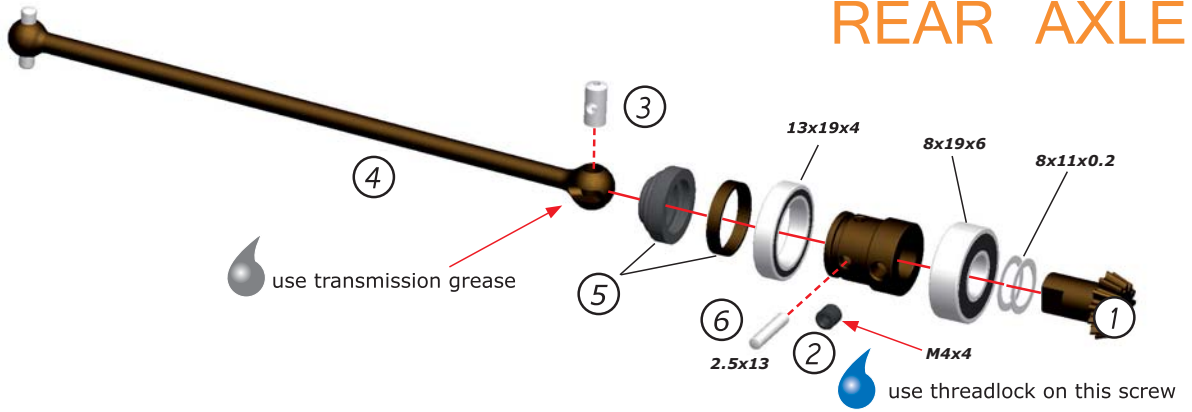

A

10

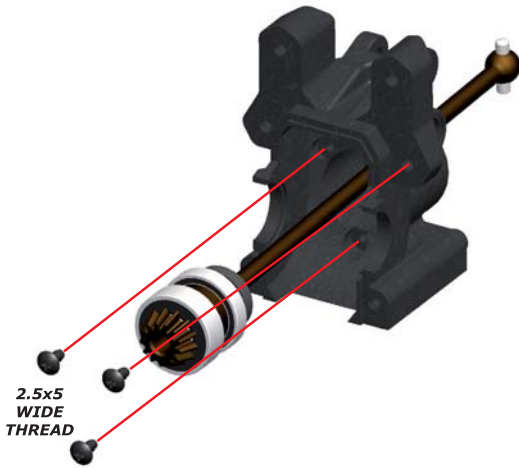

A

11

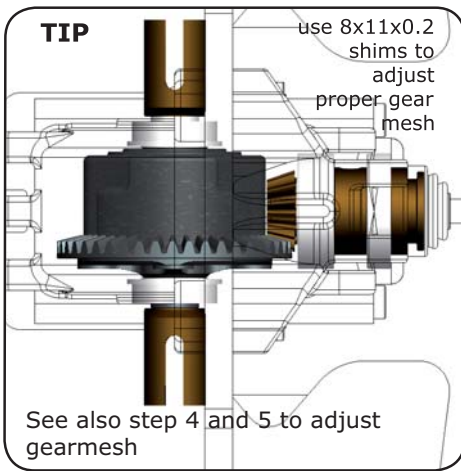

Notice orientation of differential

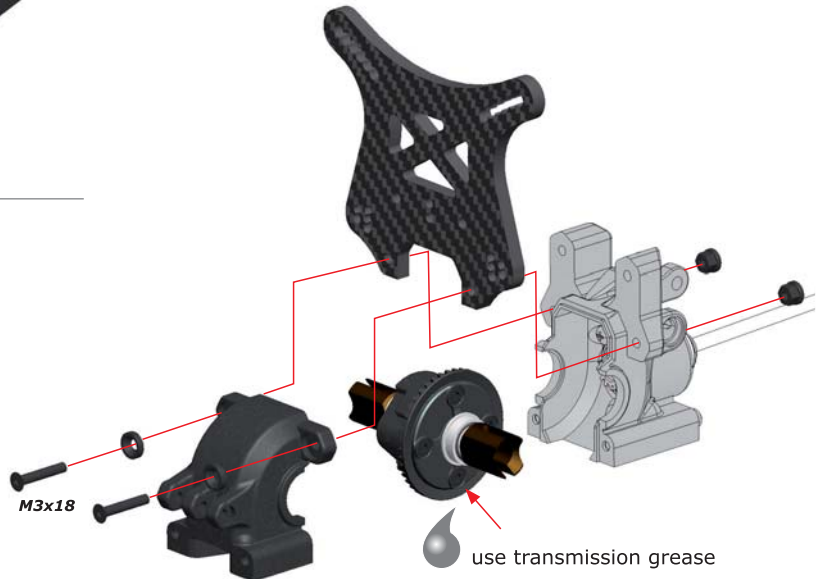

A

12

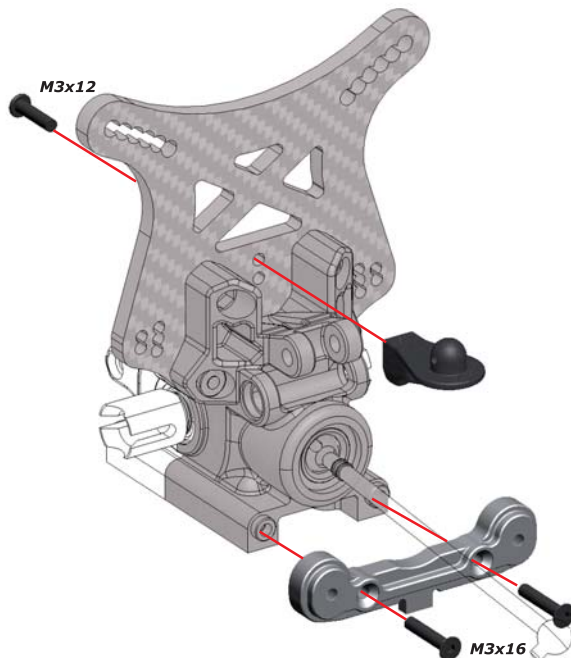

7

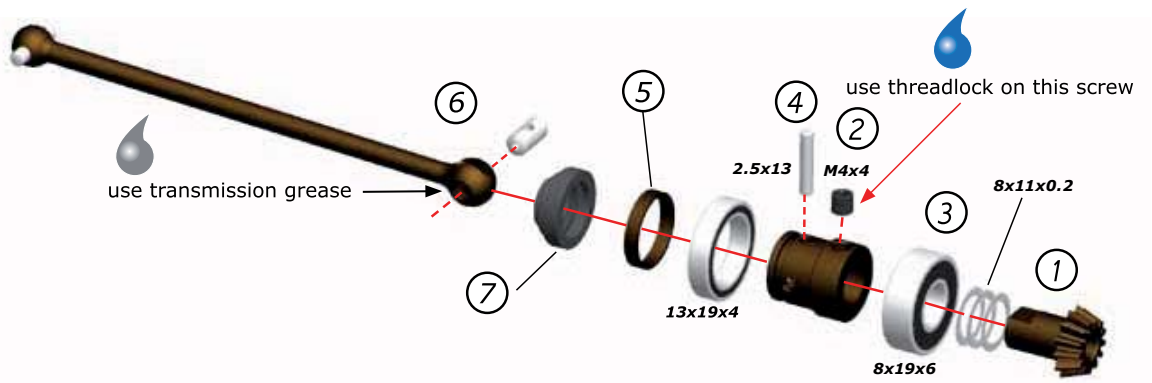

**TIP**

After building the differential with new gears a new differential case and bearings, the differential may feel a little tight. The connected parts need at least an hour run-time to create a perfect match. Attention: When you assemble the diff with too much initial play, the gears will not run-in properly and may wear quickly. After 1 or 2 hours of running the car, re-check the gear-mesh between the ring gear and the pinion. All parts should have run-in properly now. You may add one or more extra shims on the pinion or ring-gear, start off by placing 1 x 0.1mm more, and try again.

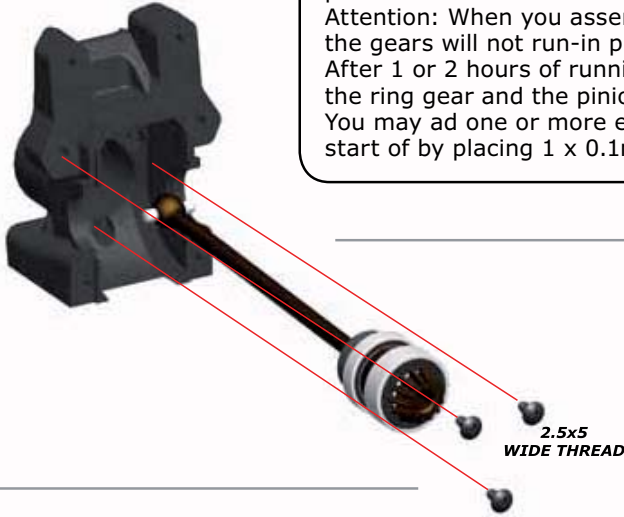

**TIP**

use 8x11x0.2 shims to adjust proper gear mesh

See also step 4 and 5 to adjust gearmesh

Notice orientation of differential

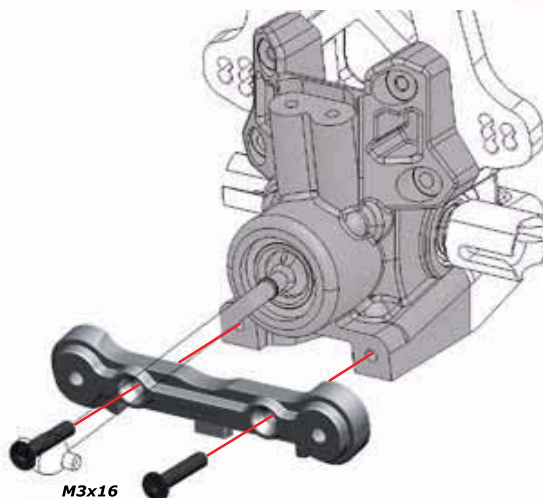
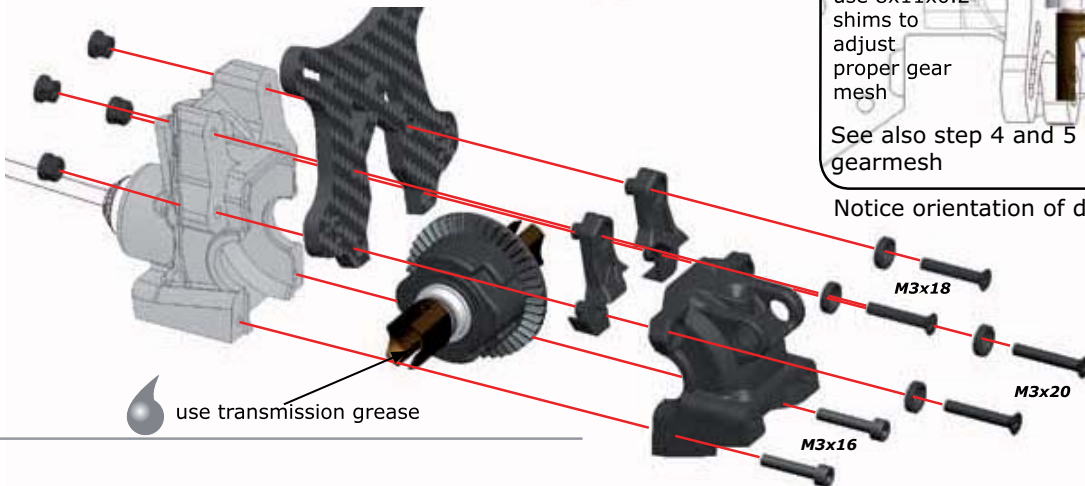

# SIDE-GUARD / RADIO ASSEMBLY

C

1

BAG  
8

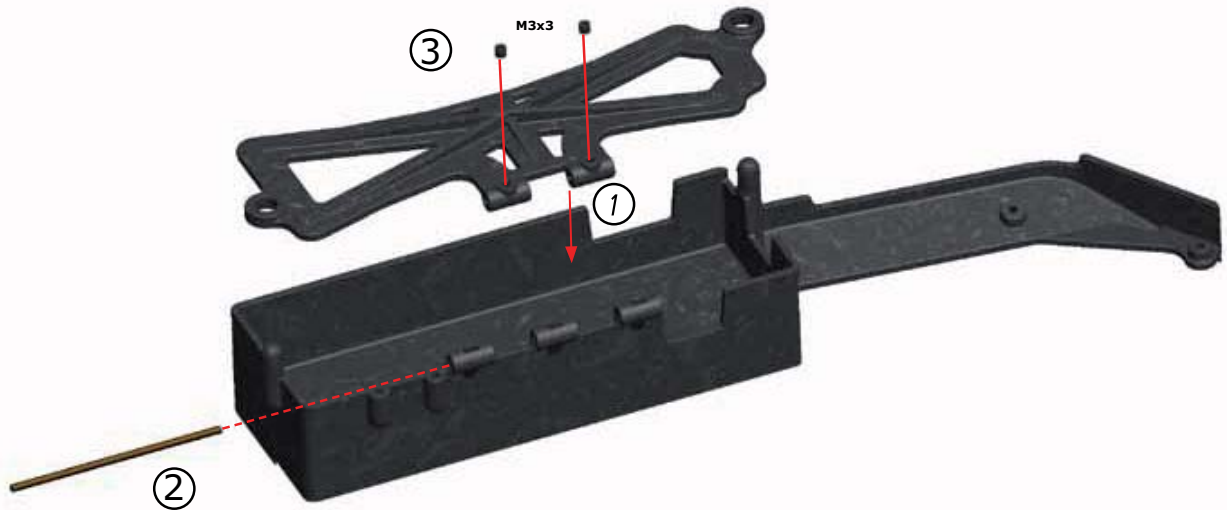

C

2

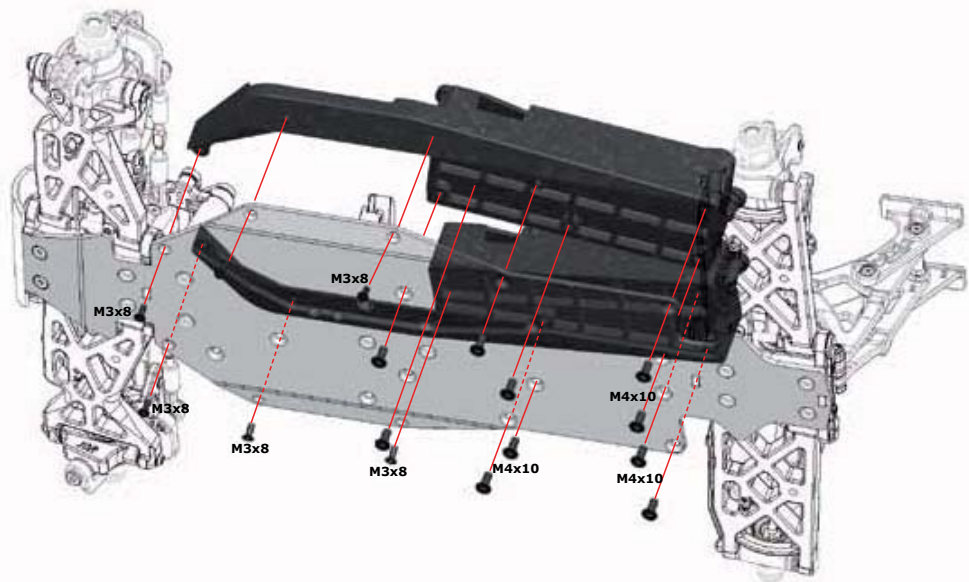

C

3

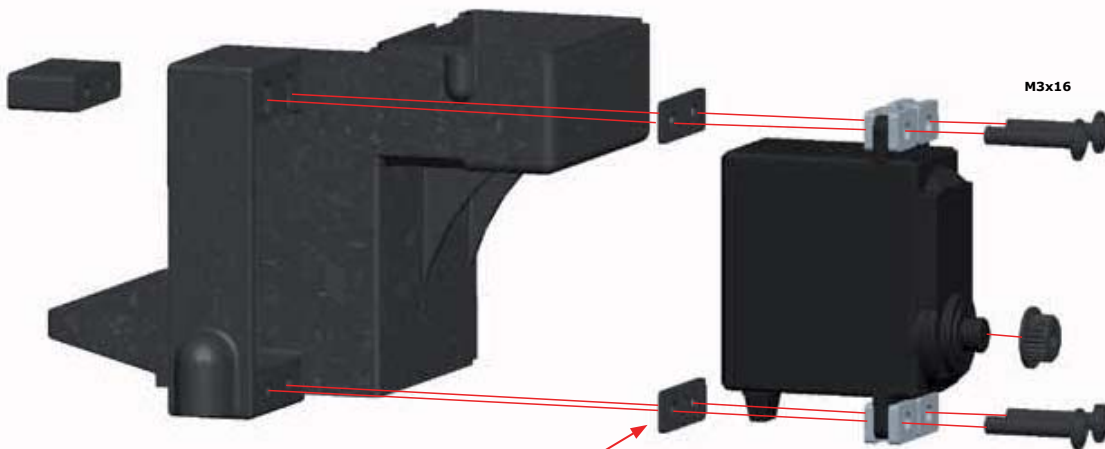

Use shims to allow servolever to clear radiobox by 0.5 to 1.0mm (see step C6)

**Inserts:**  
23T Sanwa / KO / JR  
24T Hitec  
25T Futaba

C

4

NOT INCLUDED

Adhesive

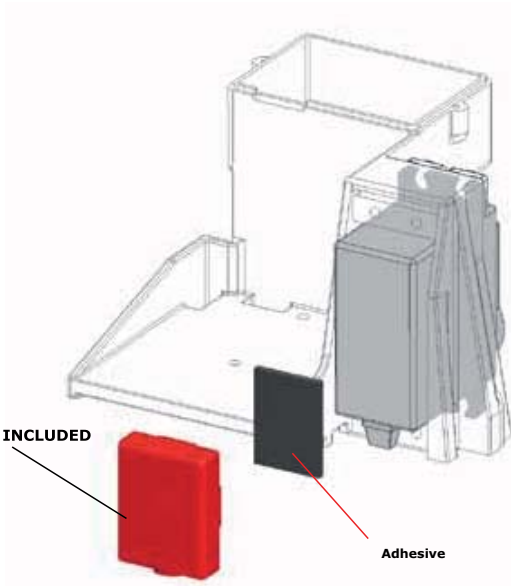

C

5

NOT INCLUDED

Adhesive

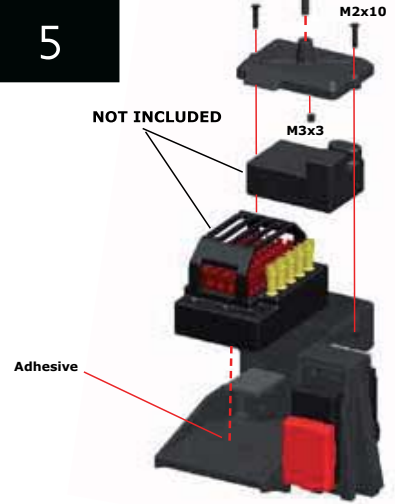

C

6

M3x12

M3x8

Place locktight on m3x12 screw as well as m3x8



C

7

M3x12

M4x10

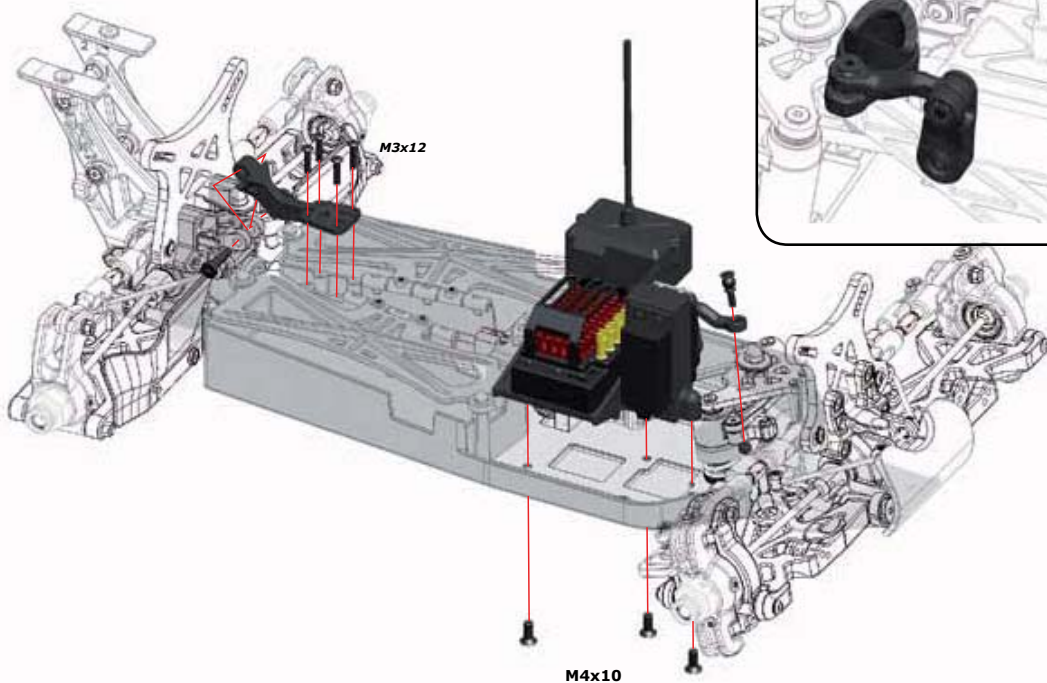

E

1

BAG  
11

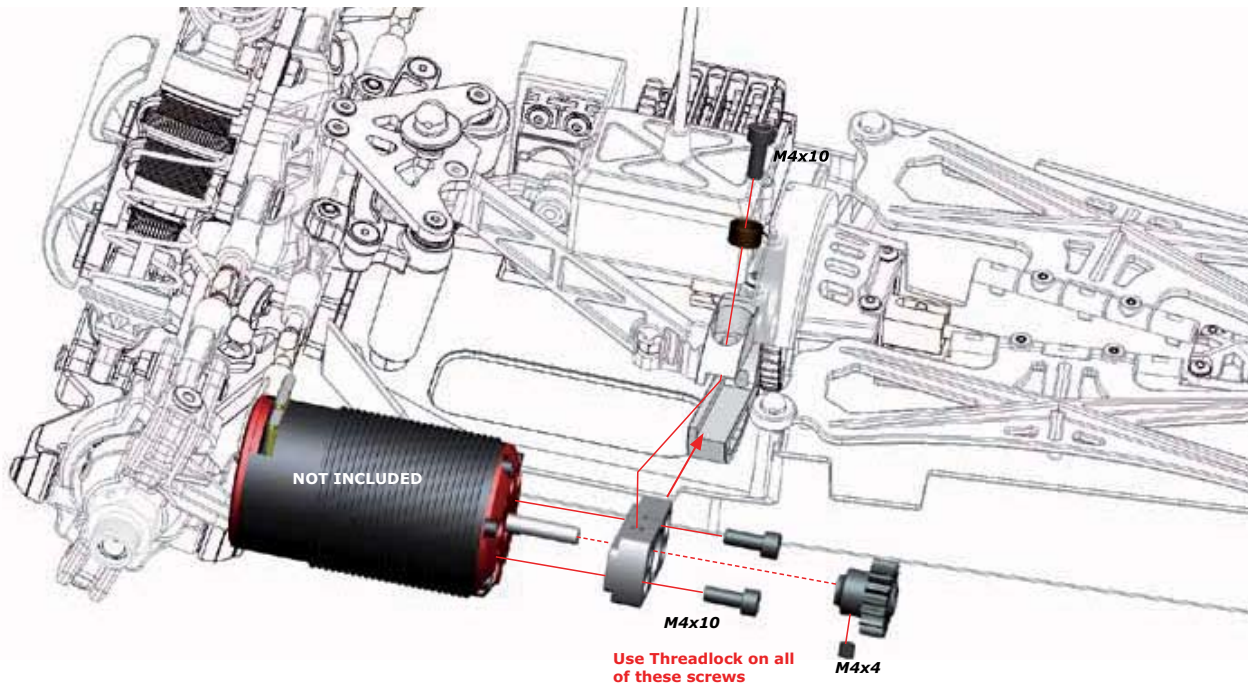

E

2

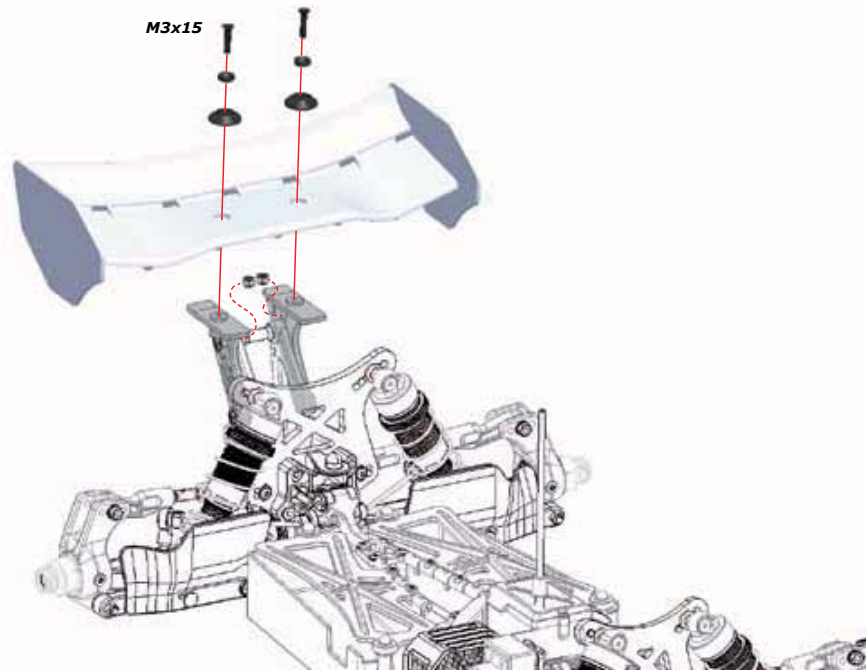

E

3

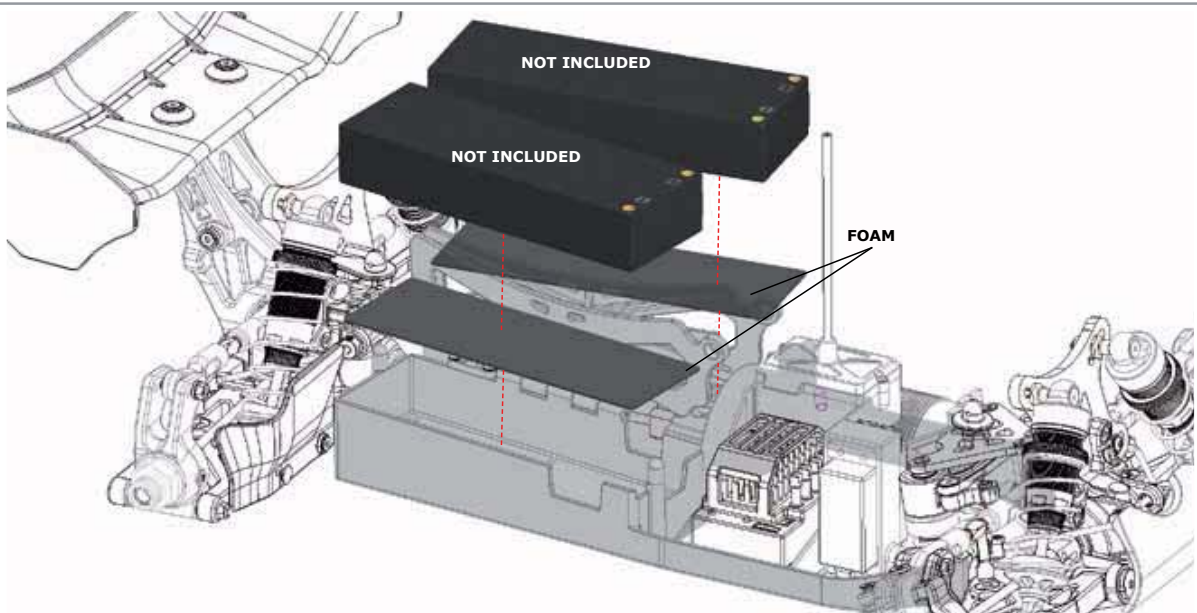

23