

DRIVER, TRACK AND RESULTS

DRIVER	Paul Ciccarello	COUNTRY	USA	WEATHER	AIR TEMP	60	TRACK TEMP	<input type="checkbox"/> DRY <input checked="" type="checkbox"/> INTERMEDIATE <input type="checkbox"/> WET
RACE	DNC	DATE	2018	QUALY POS.	STARTING POS.	FINAL POS.	FASTEST LAP	
TRACK	Fear Farm	TYPE	<input type="checkbox"/> TIGHT <input type="checkbox"/> MEDIUM <input type="checkbox"/> OPEN <input checked="" type="checkbox"/>	GRIP	<input type="checkbox"/> LOW <input type="checkbox"/> MEDIUM <input checked="" type="checkbox"/> HIGH <input type="checkbox"/>			
SURFACE CONDITION	<input type="checkbox"/> SMOOTH <input checked="" type="checkbox"/> ROUGH <input type="checkbox"/>							
TYPE	<input checked="" type="checkbox"/> HARD PACKED <input type="checkbox"/> CLAY <input type="checkbox"/> MULTI/SURFACE <input type="checkbox"/> GRASS <input checked="" type="checkbox"/> BLUE GROOVE <input checked="" type="checkbox"/> DIRT <input type="checkbox"/> ASTRO-TURF <input type="checkbox"/>							

FRONT SHOCK ABSORBERS		REAR	
425 cst	OIL	450 cst	
Purple V3	SPRINGS	Red V3	
0 mm	REBOUND	0 mm	
N° HOLES 5	Ø 1.5 mm	PISTONS N° HOLES 5	Ø 1.6 mm
<input type="checkbox"/> BLADDER	SEAL	<input type="checkbox"/> BLADDER	
<input checked="" type="checkbox"/> EMULSION	TYPE	<input checked="" type="checkbox"/> EMULSION	

FRONT ANTI-ROLL BARS		REAR	
<input type="checkbox"/> 1.8	<input type="checkbox"/> 2.0	<input type="checkbox"/> 1.8	<input type="checkbox"/> 2.0
<input type="checkbox"/> 2.3	<input checked="" type="checkbox"/> 2.7	<input type="checkbox"/> 2.3	<input checked="" type="checkbox"/> 2.7

DIFFERENTIAL OIL		
FRONT DIFF	CENTER DIFF	REAR DIFF
7 cst	7 cst	3 cst

GEARING	
CLUTCH BELL	13 Teeth
SPUR GEAR	48 Teeth

CLUTCH	
CLUTCH BELL	FLYWHEEL
<input checked="" type="checkbox"/> STANDARD <input type="checkbox"/> VENTED	<input type="checkbox"/> STEEL <input checked="" type="checkbox"/> ALU
CLUTCH SHOES	CLUTCH SPRINGS
SHOE TYPE <u>alu</u> x 2 with SPRINGS TYPE <u>med</u> mm	
SHOE TYPE <u>yellow</u> x 2 with SPRINGS TYPE <u>hard</u> mm	

ENGINE, PIPE AND FUEL			
ENGINE BRAND	Pico	TYPE	Robert Battle
HEADSHIMS	mm	GLOWPLUG	5
EXHAUST PIPE	213	MANIFOLD	
FUEL BRAND	Nitro Pro	NITRO	25 %

FLEX CONFIGURATION	
ENGINE MOUNT	<input type="checkbox"/> STANDARD <input checked="" type="checkbox"/> MONOBLOCK

AERODYNAMIC CONFIGURATION	
BODY	<input type="checkbox"/> STANDARD <input checked="" type="checkbox"/> HIGH DOWNFORCE <input type="checkbox"/> OTHER
WING	
TYPE <u>std</u>	WING PLATES <input type="checkbox"/> 2° <input checked="" type="checkbox"/> 4° <input type="checkbox"/> 6°
GURNEY STRIP <input type="checkbox"/> YES <input checked="" type="checkbox"/> NO	CENTER FOIL <input type="checkbox"/> YES <input type="checkbox"/> NO

FRONT TIRES		REAR	
JC	MAKE	JC	
TYPE			
INSERTS			
JC	WHEELS	JC	

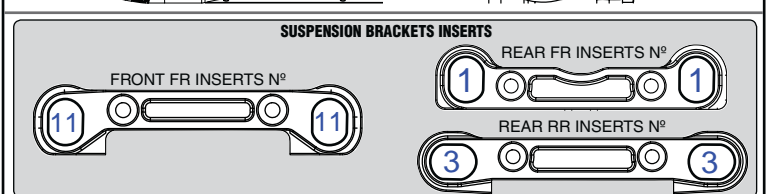
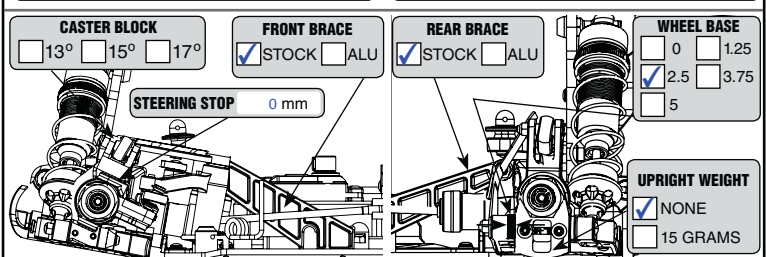
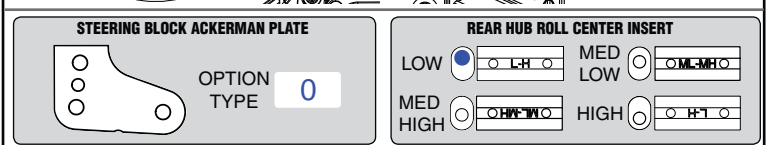
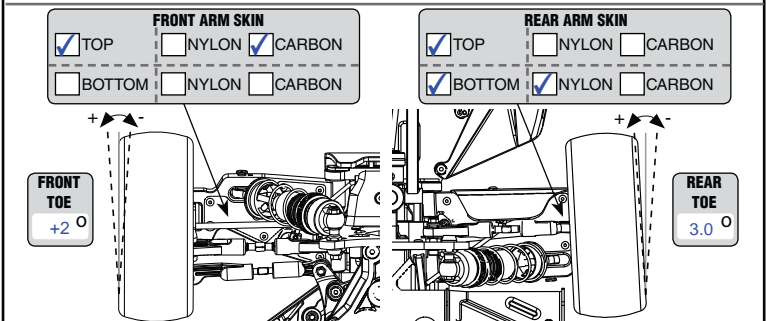
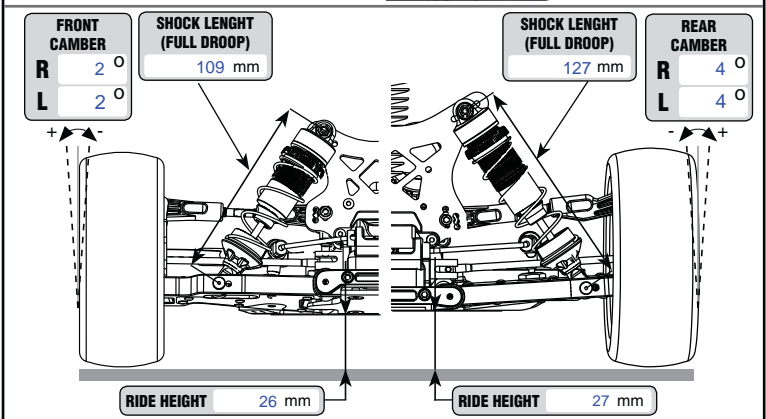
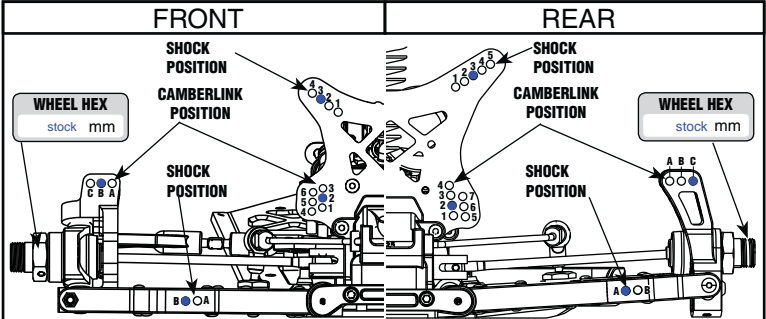

REMARKS ride height measured no body full tank, 6 mm bump steer washers total 19 deg castor blocks