

DRIVER, TRACK AND RESULTS

DRIVER	Carlos Durães	COUNTRY	Italy	WEATHER	AIR TEMP	7	TRACK TEMP	<input checked="" type="checkbox"/> DRY <input type="checkbox"/> INTERMEDIATE <input type="checkbox"/> WET			
RACE	IBR-Padova	DATE	08/01/2018	QUALY POS.		STARTING POS.		FINAL POS.		FASTEST LAP	40.5
TRACK	Padova	TYPE	<input checked="" type="checkbox"/> TIGHT <input type="checkbox"/> MEDIUM <input type="checkbox"/> OPEN	GRIP	<input checked="" type="checkbox"/> LOW <input type="checkbox"/> MEDIUM <input type="checkbox"/> HIGH						
SURFACE CONDITION	<input checked="" type="checkbox"/> SMOOTH <input type="checkbox"/> ROUGH										
TYPE	<input checked="" type="checkbox"/> HARD PACKED <input type="checkbox"/> CLAY <input type="checkbox"/> MULTI/SURFACE <input type="checkbox"/> GRASS <input type="checkbox"/> BLUE GROOVE <input type="checkbox"/> DIRT <input type="checkbox"/> ASTRO-TURF										

FRONT SHOCK ABSORBERS		REAR	
40 WT Losi cst	OIL	25 WT Losi cst	
Blue V3	SPRINGS	Pink V3	
10 mm	REBOUND	10 mm	
N° HOLES 8	Ø 1.3 mm	PISTONS N° HOLES 8	Ø 1.3 mm
<input checked="" type="checkbox"/> BLADDER	SEAL	<input checked="" type="checkbox"/> BLADDER	
<input type="checkbox"/> EMULSION	TYPE	<input type="checkbox"/> EMULSION	

FRONT ANTI-ROLL BARS		REAR	
<input type="checkbox"/>	<input type="checkbox"/>	<input type="checkbox"/>	<input checked="" type="checkbox"/>
1.8	2.0	2.3	2.5
2.3	2.5	2.7	2.7

DIFFERENTIAL OIL		
FRONT DIFF	CENTER DIFF	REAR DIFF
7K cst	10K cst	5K cst

GEARING	
CLUTCH BELL	13 Teeth
SPUR GEAR	47 Teeth

CLUTCH	
<input checked="" type="checkbox"/> STANDARD <input type="checkbox"/> VENTED	<input checked="" type="checkbox"/> STEEL <input type="checkbox"/> ALU
CLUTCH SHOES	CLUTCH SPRINGS
SHOE TYPE Alumínio x 3 with SPRINGS TYPE Green mm	
SHOE TYPE Carbon Yellow x 1 with SPRINGS TYPE 0.9 mm	

ENGINE, PIPE AND FUEL			
ENGINE BRAND	OS Spec II	TYPE	
HEADSHIMS	mm	GLOWPLUG	P3
CARB Ø	6 mm		
EXHAUST PIPE	2090	MANIFOLD	Original
FUEL BRAND	Nitrolux	NITRO	25 %

FLEX CONFIGURATION	
ENGINE MOUNT	<input type="checkbox"/> STANDARD <input checked="" type="checkbox"/> MONOBLOCK

AERODYNAMIC CONFIGURATION	
BODY	<input type="checkbox"/> STANDARD <input type="checkbox"/> HIGH DOWNFORCE <input type="checkbox"/> OTHER Duraes body
WING	
TYPE	Serpent 600825
WING PLATES	<input type="checkbox"/> 2° <input checked="" type="checkbox"/> 4° <input type="checkbox"/> 6°
GURNEY STRIP	<input type="checkbox"/> YES <input type="checkbox"/> NO
CENTER FOIL	<input type="checkbox"/> YES <input type="checkbox"/> NO

FRONT TIRES		REAR	
AKA	MAKE	AKA	
Typo Super Soft	TYPE	Typo Super Soft	
red	INSERTS	red	
Serpent	WHEELS	Serpent	

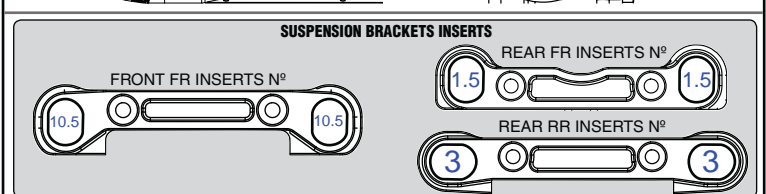
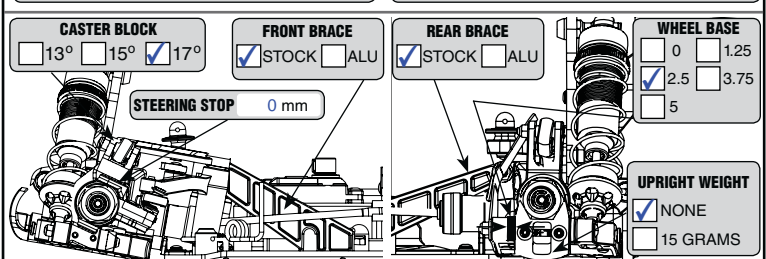
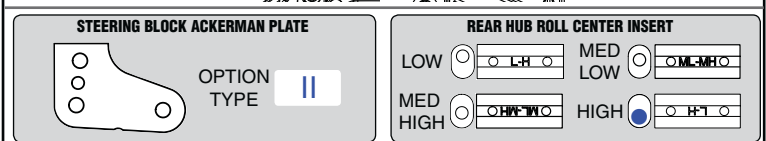
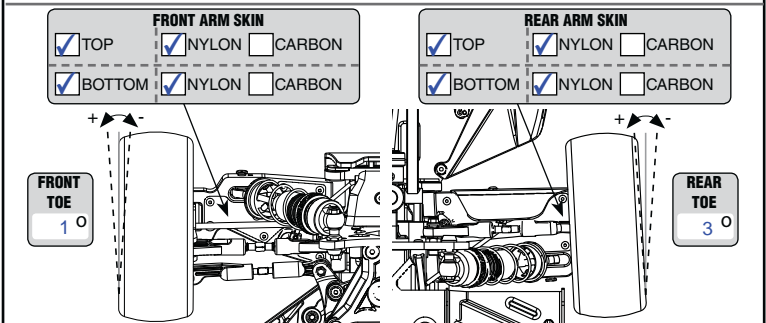
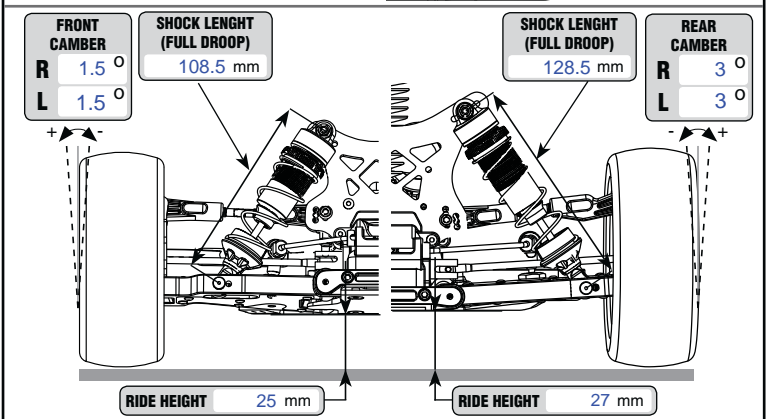
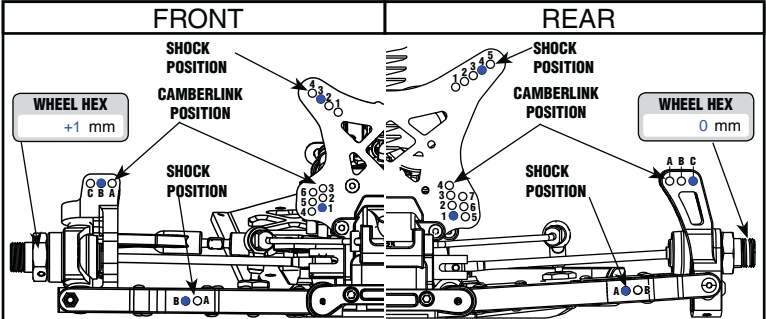

REMARKS	Front wing Adittive at the tires.
----------------	-----------------------------------